



SERIES 40PF 6 x 5 x 13 FM

FILE NO: F40.56
 DATE: Feb. 2, 2011
 SUPERSEDES: F40.56
 DATE: Mar. 6, 2008

End Suction Pump

DIESEL DRIVEN

SUBMITTAL

JOB: _____ REPRESENTATIVE: _____

 ENGINEER: _____ ORDER NO: _____ DATE: _____
 SUBMITTED BY: _____ DATE: _____
 CONTRACTOR: _____ APPROVED BY: _____ DATE: _____

TAG/REF:								
PUMP DATA	FLOW	HEAD	ENGINE DATA	HP	RPM	BAT. VOLTAGE	TANK SIZE	OTHER

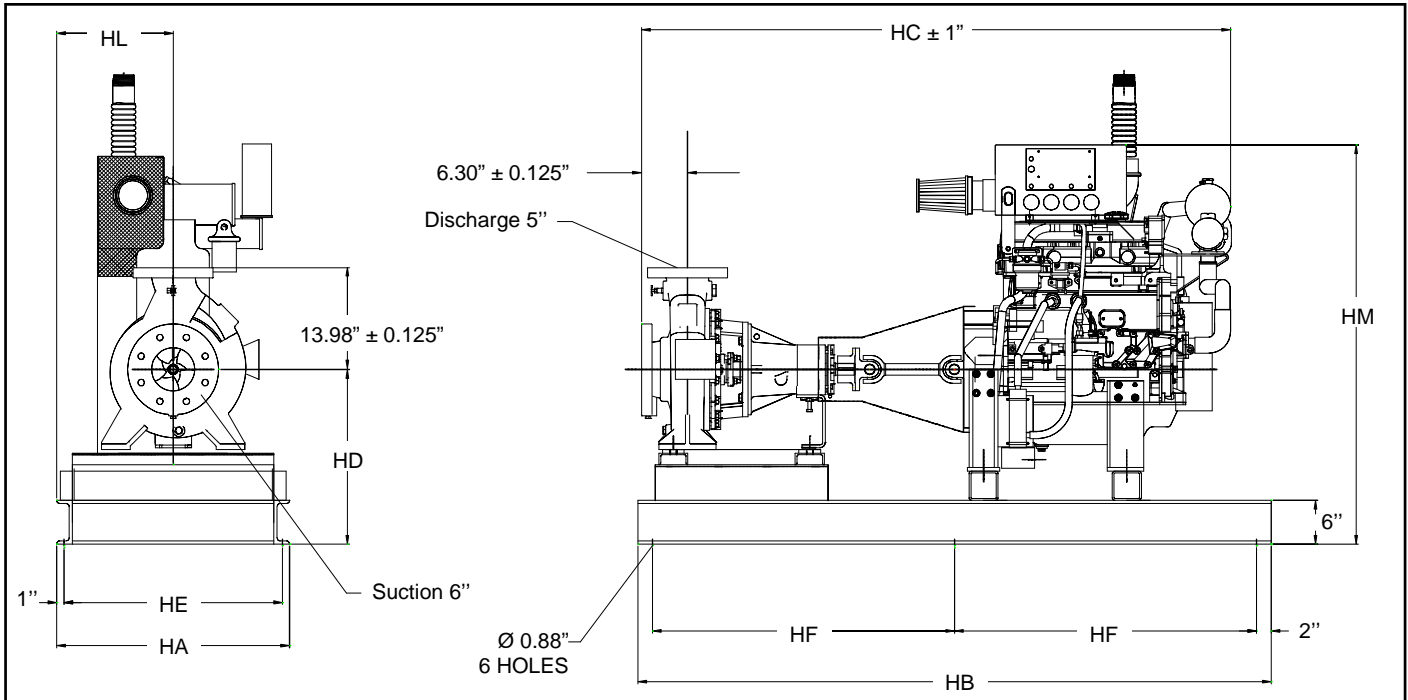

ENGINE	DIMENSIONS (Inches)								WEIGHT lbs.
	HD	HL	HA	HE	HB	HF	HM (4)	HC (4)	
CLARKE									
JU4H SERIES	24.00	16.00	32.00	30.00	88.00	42.00	55.00	81.00	1250
JU6H SERIES	23.75	16.00	32.00	30.00	96.00	46.00	54.55	93.00	2000
CUMMINS									
CFP33 SERIES	20.63	16.00	32.00	30.00	78.00	37.00	50.28	73.50	722
CFP39 SERIES	23.82	16.00	32.00	30.00	78.00	37.00	48.82	76.25	964
CFP59 SERIES	23.88	16.00	32.00	30.00	88.00	42.00	48.88	84.75	1138
CFP6E SERIES	25.00	16.00	32.00	30.00	88.00	42.00	48.50	84.50	1257

- FLANGE RATING**
- ANSI 125# STD⁽¹⁾
 - ANSI 125# SUCTION
 - ANSI 250# DISCHARGE
 - ANSI 250#
 - PN 16
- FIRE PUMP LISTING**
- UL
 - ULC
 - FM
- ACCESSORIES**
- EXHAUST SYSTEM
 - FUEL SYSTEM
 - COOLING SYSTEM (MOUNTED ON ENGINE)
 - BATTERY SYSTEM

NOTE:
 (1) STD. DISCHARGE FLANGE THICKNESS ANSI 250#
 (2) COUPLING GUARD NOT SHOWN IN OUTLINE
 (3) ALL DIMENSIONS FOR ENGINE CONNECTIONS ARE WITH REFERENCE TO ENGINE MANUFACTURER'S INSTALLATION DRAWINGS
 (4) TO BE SHIPPED LOOSE WITH PACKAGE

DO NOT USE FOR CONSTRUCTION UNLESS CERTIFIED

S. A. Armstrong Limited
 23 Bertrand Avenue
 Toronto, Ontario
 Canada, M1L 2P3
 T: 416-755-2291
 F: 416-759-9101

Armstrong Pumps Inc.
 93 East Avenue
 North Tonawanda, New York
 U.S.A. 14120-6594
 T: 716-693-8813
 F: 716-693-8970

Armstrong Integrated Limited
 Wenlock Way
 Manchester
 United Kingdom, M12 5JL
 T: +44 (0) 8444 145 145
 F: +44 (0) 8444 145 146



© S.A. Armstrong Limited 2011