



SERIES 4600F

6 x 5 x 12 F

DIESEL DRIVEN

FILE NO: F46.63  
 DATE: Aug. 17, 2006  
 SUPERSEDES: F46.63  
 DATE: Nov. 22, 2001

# HSC Pump

SUBMITTAL

JOB: \_\_\_\_\_ REPRESENTATIVE: \_\_\_\_\_  
 \_\_\_\_\_  
 ENGINEER: \_\_\_\_\_ ORDER NO: \_\_\_\_\_ DATE: \_\_\_\_\_  
 CONTRACTOR: \_\_\_\_\_ SUBMITTED BY: \_\_\_\_\_ DATE: \_\_\_\_\_  
 \_\_\_\_\_ APPROVED BY: \_\_\_\_\_ DATE: \_\_\_\_\_

**TAG/REF:**

| PUMP DATA | FLOW | HEAD | ENGINE DATA | HP | RPM | BAT. VOLTAGE | TANK SIZE | OTHER |
|-----------|------|------|-------------|----|-----|--------------|-----------|-------|
|           |      |      |             |    |     |              |           |       |

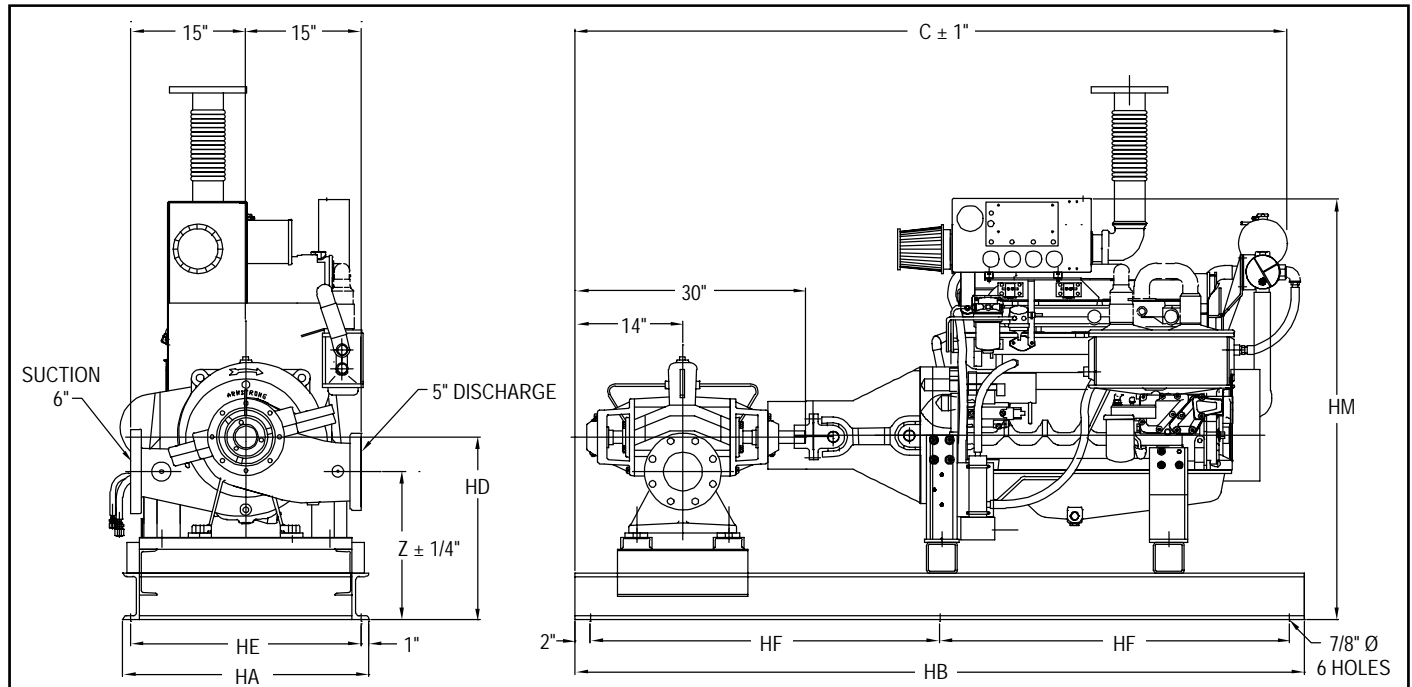

| ENGINE         | MAX. DIMENSIONS inches |         |    |    |    |        |                   |                  | WEIGHT lbs. |
|----------------|------------------------|---------|----|----|----|--------|-------------------|------------------|-------------|
|                | HD                     | Z       | HA | HE | HB | HF     | HM <sup>(3)</sup> | C <sup>(3)</sup> |             |
| <b>CLARKE</b>  |                        |         |    |    |    |        |                   |                  |             |
| JU4H SERIES    | 24                     | 19-1/2  | 32 | 30 | 82 | 39     | 55                | 76-1/2           | 1250        |
| JU6H SERIES    | 24                     | 19-1/2  | 32 | 30 | 95 | 45-1/2 | 55                | 92-1/2           | 2000        |
| JW6H SERIES    | 27-1/4                 | 22-3/4  | 32 | 30 | 95 | 45-1/2 | 58                | 91               | 2600        |
| <b>CUMMINS</b> |                        |         |    |    |    |        |                   |                  |             |
| CFP33 SERIES   | 22-5/8                 | 18-1/8  | 32 | 30 | 77 | 36-1/2 | 64                | 75               | 722         |
| CFP39 SERIES   | 23-13/16               | 19-5/16 | 32 | 30 | 77 | 36-1/2 | 67                | 76               | 964         |
| CFP59 SERIES   | 23-1/2                 | 19      | 32 | 30 | 87 | 41-1/2 | 68                | 86               | 1138        |
| CFP83 SERIES   | 23-1/2                 | 19      | 32 | 30 | 95 | 45-1/2 | 68                | 92               | 1792        |
| CFP6E SERIES   | 23-1/2                 | 19      | 32 | 30 | 87 | 41-1/2 | 68                | 83               | 1257        |

- FLANGE RATING**
- ANSI 125# STD<sup>(1)</sup>
  - ANSI 125# SUCTION
  - 250# DISCHARGE
  - ANSI 250#
  - PN 16
- FIRE PUMP LISTING**
- UL
  - ULC
  - FM
- ACCESSORIES**
- EXHAUST SYSTEM
  - FUEL SYSTEM
  - COOLING SYSTEM (MOUNTED ON ENGINE)
  - BATTERY SYSTEM

NOTE:  
 (1) STD. DISCHARGE FLANGE THICKNESS ANSI 250#  
 (2) COUPLING GUARD NOT SHOWN  
 (3) ALL DIMENSIONS FOR ENGINE CONNECTIONS ARE WITH REFERENCE TO ENGINE MANUFACTURER'S INSTALLATION DRAWINGS

RIGHT HAND ROTATION ONLY  
 (AS SHOWN)

DO NOT USE FOR CONSTRUCTION UNLESS CERTIFIED

S. A. Armstrong Limited  
 23 Bertrand Avenue  
 Toronto, Ontario  
 Canada, M1L 2P3  
 T: (416) 755-2291  
 F (Main): (416) 759-9101

Armstrong Pumps Inc.  
 93 East Avenue  
 North Tonawanda, New York  
 U.S.A. 14120-6594  
 T: (716) 693-8813  
 F: (716) 693-8970

Armstrong Holden Brooke Pullen  
 Wenlock Way  
 Manchester  
 United Kingdom, M12 5JL  
 T: +44 (0) 161 223 2223  
 F: +44 (0) 161 220 9660



© S.A. Armstrong Limited 2006

For Armstrong locations worldwide, please visit [www.armstrongpumps.com](http://www.armstrongpumps.com)