



SERIES 4600F

6 x 5 x 9.5 F

DIESEL DRIVEN

FILE NO: F46.611
 DATE: Aug. 17, 2006
 SUPERSEDES: F46.611
 DATE: Nov. 22, 2001

HSC Pump

SUBMITTAL

JOB: _____ REPRESENTATIVE: _____

ENGINEER: _____ ORDER NO: _____ DATE: _____

CONTRACTOR: _____ SUBMITTED BY: _____ DATE: _____

APPROVED BY: _____ DATE: _____

TAG/REF:								
PUMP DATA	FLOW	HEAD	ENGINE DATA	HP	RPM	BAT. VOLTAGE	TANK SIZE	OTHER

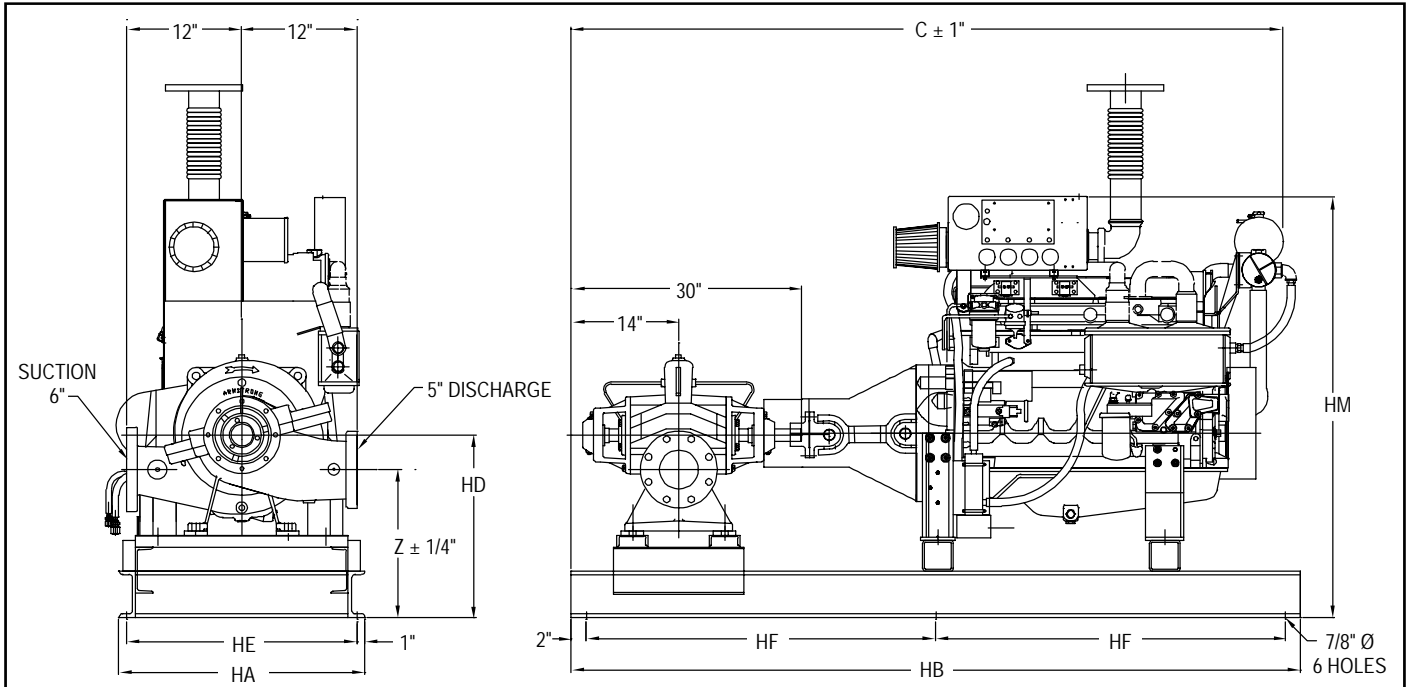

ENGINE	MAX. DIMENSIONS inches								WEIGHT lbs.
	HD	Z	HA	HE	HB	HF	HM ⁽³⁾	C ⁽³⁾	
CLARKE									
JU4H SERIES	24	19-1/2	32	30	82	39	55	76-1/2	1250
JU6H SERIES	24	19-1/2	32	30	95	45-1/2	55	92-1/2	2000
JW6H SERIES	27-1/4	22-3/4	32	30	95	45-1/2	58	91	2600
CUMMINS									
CFP33 SERIES	22-5/8	18-1/8	32	30	77	36-1/2	64	75	722
CFP39 SERIES	23-13/16	19-5/16	32	30	77	36-1/2	67	76	964
CFP59 SERIES	23-1/2	19	32	30	87	41-1/2	68	86	1138

- FLANGE RATING**
- ANSI 125# STD⁽¹⁾
 - ANSI 125# SUCTION
 - 250# DISCHARGE
 - ANSI 250#
 - PN 16
- FIRE PUMP LISTING**
- UL
 - ULC
 - FM
- ACCESSORIES**
- EXHAUST SYSTEM
 - FUEL SYSTEM
 - COOLING SYSTEM (MOUNTED ON ENGINE)
 - BATTERY SYSTEM

NOTE:

- (1) STD. DISCHARGE FLANGE THICKNESS ANSI 250#
- (2) COUPLING GUARD NOT SHOWN
- (3) ALL DIMENSIONS FOR ENGINE CONNECTIONS ARE WITH REFERENCE TO ENGINE MANUFACTURER'S INSTALLATION DRAWINGS

RIGHT HAND ROTATION ONLY

(AS SHOWN)

DO NOT USE FOR CONSTRUCTION UNLESS CERTIFIED

S. A. Armstrong Limited
 23 Bertrand Avenue
 Toronto, Ontario
 Canada, M1L 2P3
 T: (416) 755-2291
 F (Main): (416) 759-9101

Armstrong Pumps Inc.
 93 East Avenue
 North Tonawanda, New York
 U.S.A. 14120-6594
 T: (716) 693-8813
 F: (716) 693-8970

Armstrong Holden Brooke Pullen
 Wenlock Way
 Manchester
 United Kingdom, M12 5JL
 T: +44 (0) 161 223 2223
 F: +44 (0) 161 220 9660



© S.A. Armstrong Limited 2006

For Armstrong locations worldwide, please visit www.armstrongpumps.com