

VERTICAL TURBINE DIESEL FIRE PUMP | 4500 GPM WITH 14×24½ FABRICATED STEEL HEAD | SUBMITTAL

File No: F51.646
Date: JULY 15, 2013
Supersedes: F51.648
Date: AUGUST 15, 2005

Job: _____ Representative: _____
 _____ Order no.: _____ Date: _____
 Engineer: _____ Submitted by: _____ Date: _____
 Contractor: _____ Approved by: _____ Date: _____

Model: 14×19H VTF **Discharge head:** 14×24½ F

RPM: 1770 Water lube

4000 GPM: _____ T.D.H

- FM UL NFPA-20 only
- Approval Construction
- Engine model: _____
- Ragd model: _____
- Shaft model: _____
- Controller model: _____

NOTES

- Dimension based on randolph gear drive. May vary when driver adaptor is required.
- Dimensions are in inches unless otherwise indicated.
- Engine to base mounting and cooling loop to be field installed and plumbed.
- Engine oil & anti freeze/coolant may not be included.
- Gear shipped filled with oil. Check level before installation.
- Refer dwg. no. _____ for Engine dimensions.
- Not to be used for construction unless certified.

PRESS RATE	DISCHARGE FLANGE INCH (mm)					
	DA	DC	DD	DF	DG	DK
150#	21.00 (533)	18.75 (476)	17.00 (432)	14.00 (356)	1.13 (29)	1.38 (35)
300#	23.00 (584)	20.25 (514)	17.00 (432)	14.00 (356)	1.25 (32)	2.13 (54)



NO OF STG'S	DISCHARGE SIZE	RATING	RAGD	AG*	B	C	H*	I*	L	AA
	INCH (mm)		HP	INCH (mm)						
1	14.00 (356)	150	590	45.44 (1154)	35.63 (905)	1.69 (43)	18.75 (476)	28.00 (711)	—	—
3	14.00 (356)	150	750	45.44 (1154)	67.88 (1724)	2.25 (57)	18.75 (476)	28.00 (711)		
3	14.00 (356)	150	1000	62.25 (1581)	67.88 (1724)	2.25 (57)	21.00 (533)	36.88 (937)		
4	14.00 (356)	300	1000	62.25 (1581)	84.00 (2134)	2.25 (57)	21.00 (533)	36.88 (937)		
4	14.00 (356)	300	1200	54.00 (1372)	84.00 (2134)	2.25 (57)	18.00 (457)	38.00 (965)		

* Dimension based on randolph gear drive. May vary when driver adaptor is required.

SUBMITTAL
4500 GPM

Vertical turbine diesel Fire pump
4500 GPM with 14x24½ Fabricated steel head

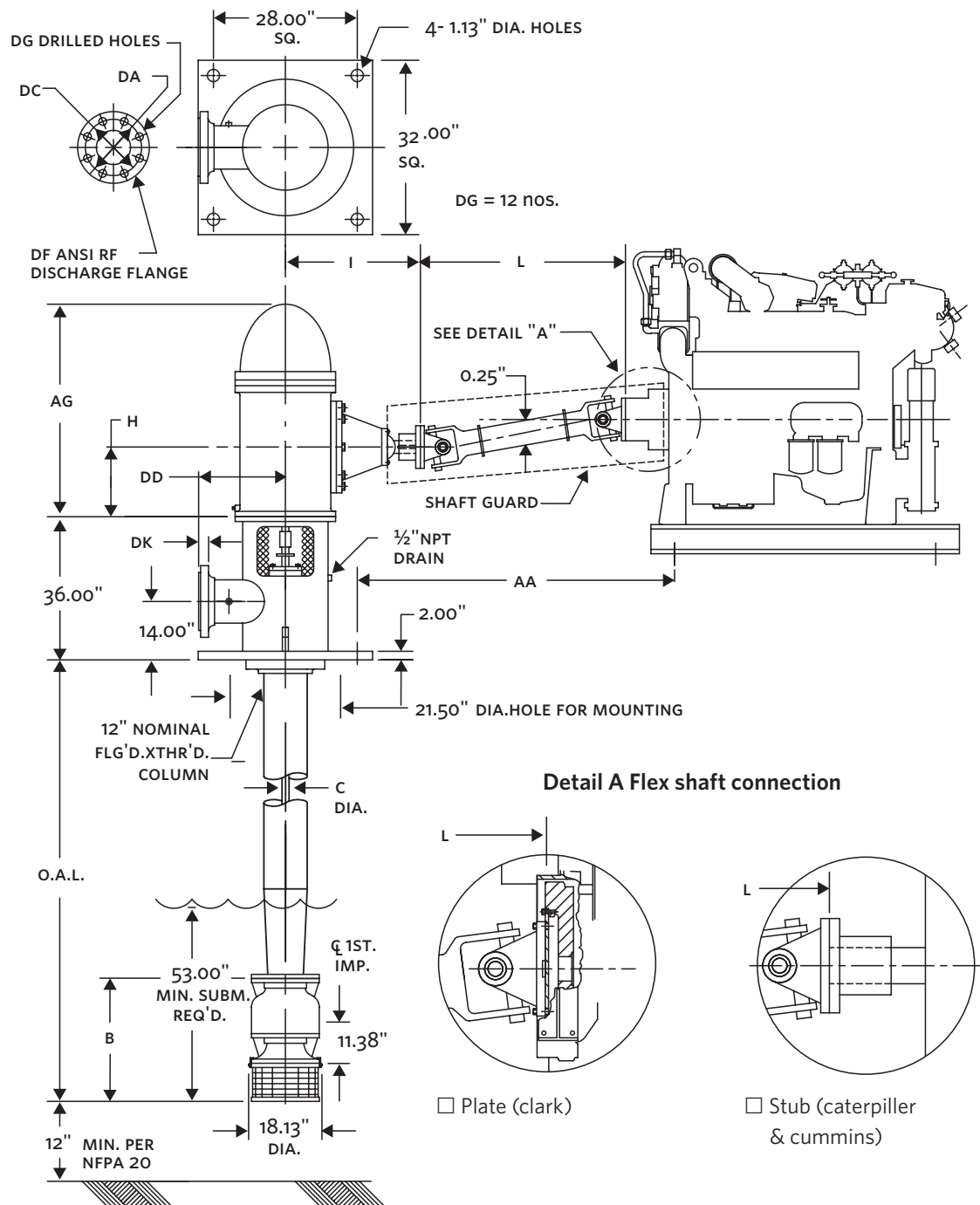

TORONTO
+1 416 755 2291

BUFFALO
+1 716 693 8813

BIRMINGHAM
+44 (0) 8444 145 145

MANCHESTER
+44 (0) 8444 145 145

BANGALORE
+91 (0) 80 4906 3555

SHANGHAI
+86 21 3756 6696

ARMSTRONG FLUID TECHNOLOGY
ESTABLISHED 1934

ARMSTRONGFLUIDTECHNOLOGY.COM