



SERIES 40PF

5 x 4 x 11.5 FM

FILE NO: F40.611
 DATE: Nov. 29, 2010
 SUPERSEDES: F40.611 & F40.631
 DATE: May 31, 2002

End Suction Pump

ELECTRIC DRIVEN

SUBMITTAL

JOB: _____ REPRESENTATIVE: _____

ENGINEER: _____ ORDER NO: _____ DATE: _____

CONTRACTOR: _____ SUBMITTED BY: _____ DATE: _____

APPROVED BY: _____ DATE: _____

TAG/REF:									
PUMP DATA	FLOW	HEAD	MOTOR DATA	HP	RPM	VOLT	PH	Hz	ENCLOSURE
SPECIAL STARTING:									

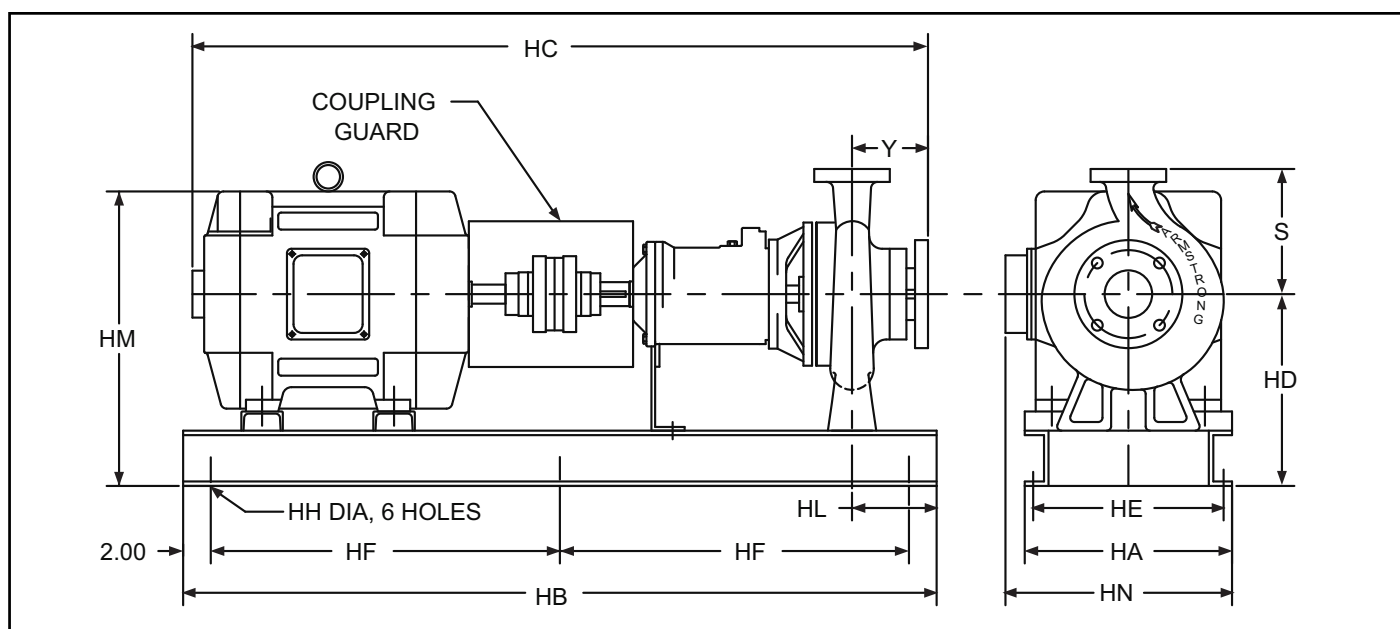

MOTOR FRAME	DIMENSIONS (in.)													WEIGHT lbs.
	HA	HB	HC	HE	HF	HH	HM	HN	HD	X	Y	HL	S	
254T	23.00	75.00	52.83	21.50	35.50	0.88	25.36	21.58	19.18	11.50	6.00	6.50	12.88	999
256T			54.57											
284TS			54.68				26.25	22.37						
286TS			56.18											
324TS			57.74				27.13	23.00						
326TS			59.24											
364TS			61.20				28.68	25.91						
365TS														
404TS														
405TS			64.70				28.68	2473						

FLANGE RATING
 ANSI 125# STD
 ANSI 250#
 PN 16

FIRE PUMP LISTING
 UL
 ULC
 FM

DO NOT USE FOR CONSTRUCTION UNLESS CERTIFIED

S. A. Armstrong Limited
 23 Bertrand Avenue
 Toronto, Ontario
 Canada, M1L 2P3
 T: 416-755-2291
 F: 416-759-9101

Armstrong Pumps Inc.
 93 East Avenue
 North Tonawanda, New York
 U.S.A. 14120-6594
 T: 716-693-8813
 F: 716-693-8970

Armstrong Integrated Limited
 Wenlock Way
 Manchester
 United Kingdom, M12 5JL
 T: +44 (0) 8444 145 145
 F: +44 (0) 8444 145 146



© S.A. Armstrong Limited 2010

For Armstrong locations worldwide, please visit www.armstrongintegrated.com